

# The Proven Mixproof Range

## SMP-TO Sanitary Mixproof Tank Outlet Valve

**Application**

SMP-TO is a sanitary pneumatic seat valve. SMP-TO is designed for mixproof tankoutlet operation when cleaning of the line right up to the bottom of the tank is required.

**Working principle**

SMP-TO is remote-controlled by means of compressed air. The valve is a normally closed (NC) valve.

The valve has two independant plug seals, forming a leakage chamber under atmospheric pressure between them. Leaking product flows into the leakage chamber and is discharged through the leakage outlet.

When the valve is open the leakage chamber is closed (no product loss during operation). The product can then flow from the tank to the line.

The independent seat lift of the lower plug provides easy cleaning without the need of external CIP (see fig. 2).

The lower plug of SMP-TO is seated so that it is insensitive to high pressure and water hammer in the line.

**Standard design**

The valve consists of one valve body, which is connected to the tank flange with screws and two flange halves. The body can be turned in any position if the screws are slightly loosened.

The tank flange is welded directly into the tank.

The tank flange is supplied with TÜV approval and inspection certificate 3.1.B according EN 10204.



Fig. 1. SMP-TO valve with body combination 30.

**Valve body combinations**

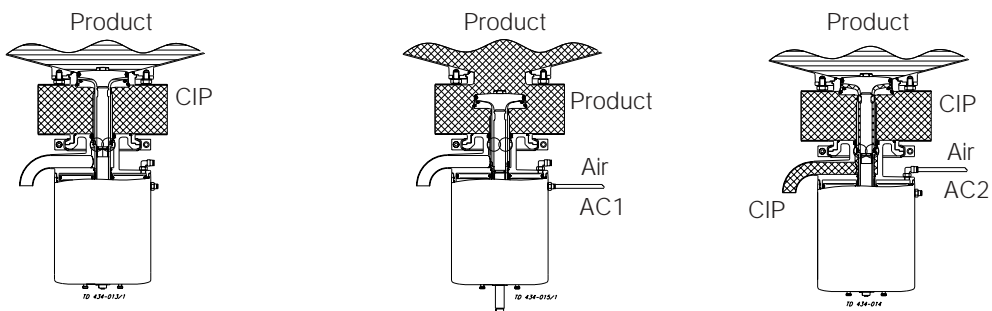
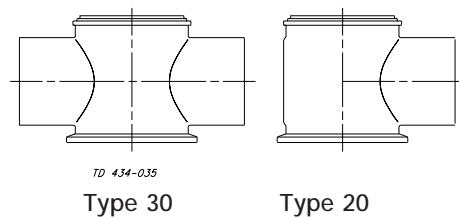
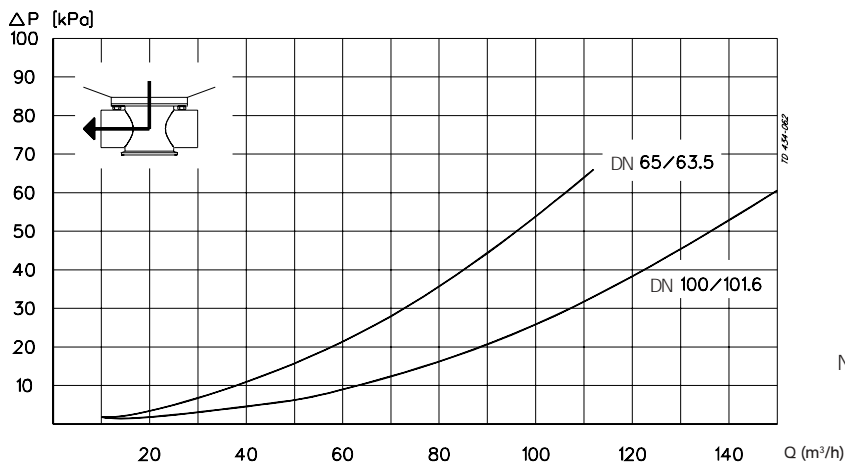
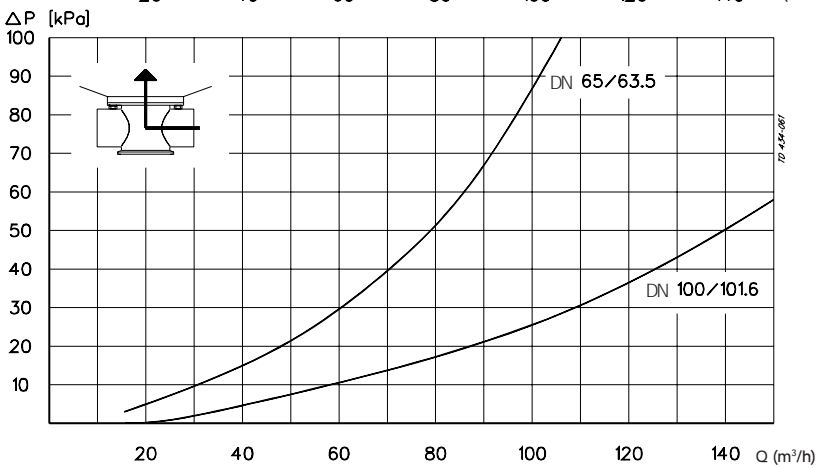
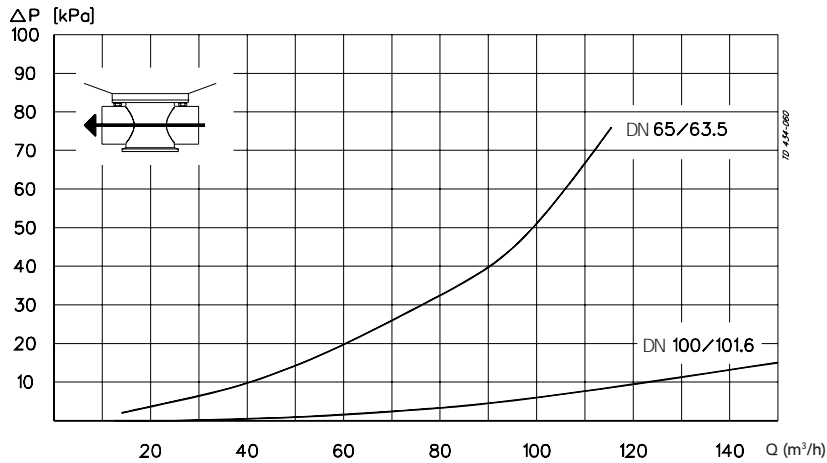

Fig.2. Operation/cleaning.

Pressure drop/capacity diagrams



NOTE! For the diagrams the following applies:  
 Medium: Water (20°C).  
 Measurement: In accordance with VDI 2173.

Size	CIP liquid capacities - Kv values
All sizes	2.5

Formula to calculate CIP flow during seat lift:  
 (for liquids with comparable viscosity and density to water).

$$Q = K_v \cdot \sqrt{\Delta p}$$

Q = CIP flow (m³/h).

K<sub>v</sub> = Flow (m³/h) through the CIP outlet at a pressure drop of 1 bar (see the above table).

Δp = CIP pressure (bar).

Dimensions (mm)

Size mm	63.5	101.6	65	100
mm		mm	DN	DN
A *	590	620	590	620
A <sub>1</sub>	422	456	422	456
A <sub>2</sub>	470	504	470	504
OD <sub>1</sub>	63.5	101.6	70	104
ID <sub>1</sub>	60.3	97.6	66	100
t <sub>1</sub>	1.6	2.0	2.0	2.0
OD <sub>2</sub>	28	28	28	28
ID <sub>2</sub>	25	25	25	25
t <sub>2</sub>	1.5	1.5	1.5	1.5
E	73	88	70	87
F	48	48	48	48
G	133.5	133.5	133.5	133.5
H	199	199	199	199
J	210	210	210	210
K ± 0.5	206	206	206	206
L ± 0.2	2	2	2	2
M/ISO clamp	21	21		
M/ISO male	21	21		
M/DIN male			25	30
M/SMS male	24	35		
M/BS male	22	27		
Weight (kg)	32.5	32.5	32.5	32.5

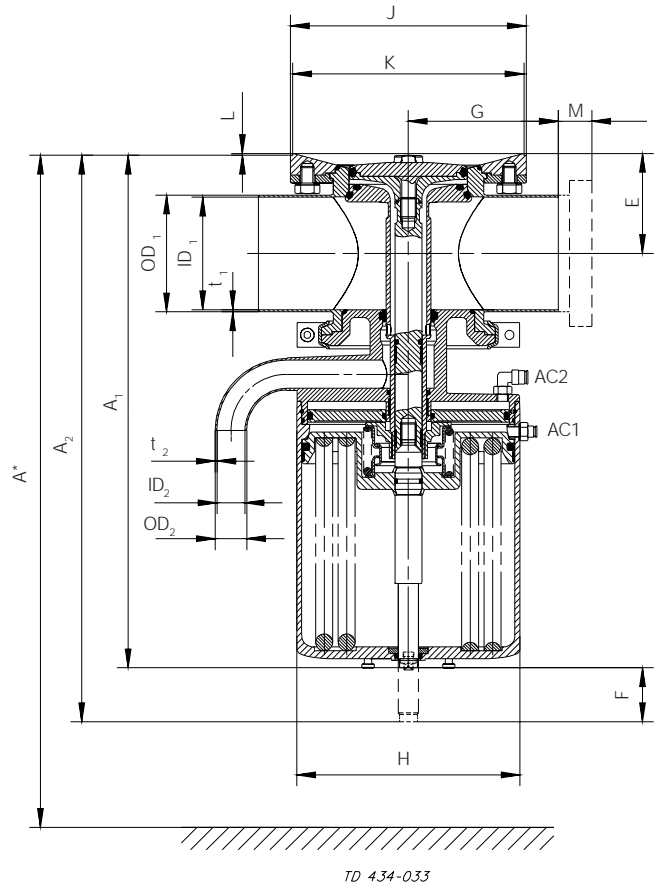

Fig. 3. Dimensions.

\* Min. installation measure to allow for removal of the actuator.

**Air connections:**

AC1 and AC2: R 1/8" (BSP), internal thread.

AC1: Open valve.

AC2: Seat cleaning, lower plug.

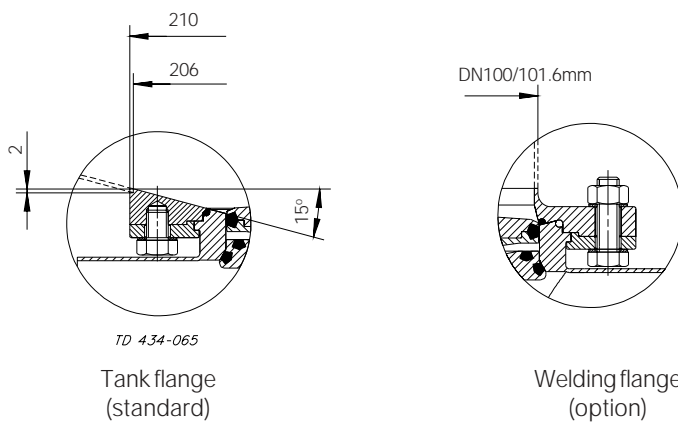

**Technical data**

Max. pressure in tank (higher pressure will open the valve): ..... 800 kPa (8 bar).  
 Min. pressure: ..... Full vacuum.  
 Max. pressure in line against which the valve can open when pressure in tank is 0: ..... 8 bar (when air pressure is 7 bar).  
 Temperature range: ..... -10°C to +140°C (EPDM).  
 Air pressure: ..... 500 to 700 kPa (5-7 bar).

Air consumption (litres free air)	
Size	63.5, 101.6 mm DN65, DN100
Lift, lower plug	0.25 x air pressure (bar)
Opening	1.85 x air pressure (bar)

**Materials**

Product wetted steel parts: ..... Acid-resistant steel 1.4401 (316 L).  
 Other steel parts: ..... Stainless steel 1.4301 (304).  
 Product wetted seals: ..... EPDM rubber.  
 Other seals: ..... Nitrile (NBR).  
 Finish: ..... Semi bright.

**Options**

- A) Male parts or clamp liners in accordance with required standard.
- B) *ThinkTop*<sup>®</sup>
- C) Welding flange for stub tube welding at the bottom of the tank (tube DN100/101.6 mm).
- D) Product wetted seals in Nitrile (NBR) or Fluorinated rubber (FPM).
- E) Service tool for the actuator.
- F) Tool for plug seals.

**Ordering**

Please state the following when ordering:

- Valve type.
- Valve port combination: Type nos.
- Connections if not welding ends.
- Welding flange, if not standard tank flange.
- Other options.

**Note!** For further details, see also PD 65036 and instruction IM 70785.

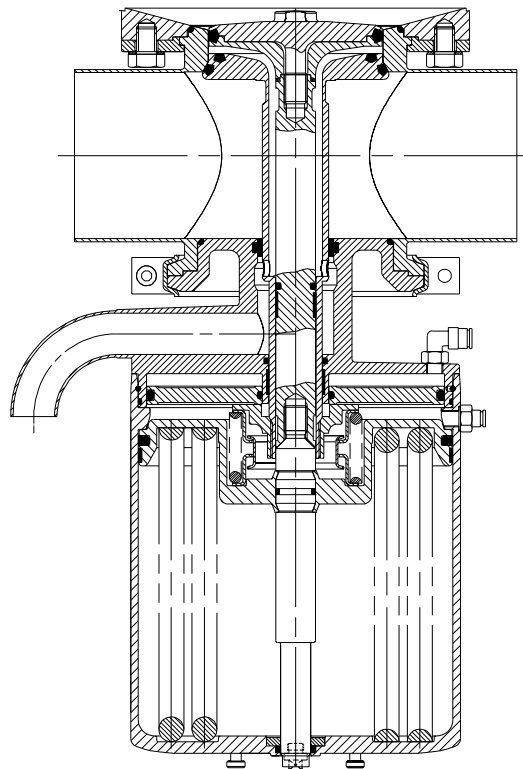

TD 434-034

Fig. 4. Details of SMP-TO.