

Leave Surveillance to the Top

ThinkTop® Digital 8-30 VDC PNP/NPN

Application

The *ThinkTop*® is designed to ensure optimum valve control in conjunction with Alfa Laval sanitary valves and it is compatible with all major PLC systems (Programmable Logic Controller with PNP/NPN interface). It is for use in food, dairy and brewery installations and in biopharmaceutical applications.

Working Principle

The *ThinkTop*® is a control head including indication units and solenoid valves to control all kinds of processing valves. It is used to control and supervise pneumatic valves and it is mounted on top of the valve. It receives signals from a PLC to control the valve and it sends feedback signals to the PLC to indicate when the valve is in a certain position.

To adapt the sensor unit to the specific valve and to the application, the user sets up the *ThinkTop*® either by the local keys or by using the key pad (which is ordered separately). When using the key pad it is not necessary to dismantle the top unit.

Sensor System

Unique "No Touch" sensor system without any mechanical sensor adjustments. A magnet is mounted on the valve stem and the magnetic field (axial) is detected by sensor chips inside the sensor unit. The measuring angle from each chip is used to locate the current position of the valve stem with an accuracy of ± 0.1 mm. Note that the distance to the magnet can be $5 \text{ mm} \pm 3 \text{ mm}$.

Feedback Signals

The sensor system can be used for 4 feedback signals + 1 status signal = 5 digital PNP/NPN feedback signals. Selection of PNP or NPN is done by a jumper. 2 of the feedback signals can be external sensors if necessary.

The status signal is used for detection of the following:

- Set-up is in progress.
- Internal error.
- Maintenance is required (based on time and/or the self adjustment programme).

The LEDs are constantly indicating the status of the unit: Valve



Fig. 1. *ThinkTop*®

position, solenoid activated, setup and local fault indication, maintenance and seat-lift.

Standard Design

The *ThinkTop*® has a simple, modular and robust design which ensures a quick and easy assembly/disassembly. It consists of a base containing a sensor unit with LEDs, an activator stem, terminals for internal electrical connection, solenoid valves and a shell. See also Fig. 2 "Basic Design". It is prepared for upgrading and is exchangeable. The design is hygienic and easy to clean.

Features

Tolerance Programmes

Individual tolerance programmes for all Alfa Laval sanitary valve types are part of the *ThinkTop*® concept ensuring correct feedback to the PLC for open and closed valve position. If the function is disabled the tolerance band will be ± 5 mm.

Self Adjustment (SRC/ARC valves only)

The self adjustment feature is an exceptional aspect of the *ThinkTop*® design. A programme can be activated to allow an adjustment of the tolerance band if the seals in the valve are being compressed or are worn. When the tolerance band of the unit has been adjusted 0.3 mm, an alert warning will appear in the form of a status signal and a flashing maintenance LED. After 0.5 mm adjustment an alarm warning appears: Loss of feedback signal, status signal and steady maintenance light indicating that a replacement of the seal is necessary.

Built-in Maintenance Monitor

The unit can be preset to indicate when the time for maintenance of the valve has been reached. A status signal and flashing maintenance LED can be programmed to return after 3, 6, 9 or 12 months or more.

Other Features

Another very important fact is that the setup is kept until programmed otherwise even during failure in the power supply.

The accurate sensor system enables indication of seatlift to be integrated in the top unit.

Materials

Plastic parts:	Nylon PA 12.
Steel parts:	Stainless steel AISI 304 and 316.
Seals:	Nitrile (NBR). EPDM rubber for SMP-EC activator stem.

Technical Data

Sensor System:

Sensor accuracy:	$\pm 0,1$ mm
Distance to magnet:	5 ± 3 mm
Stroke length:	0.1 - 80 mm

Electrical connection

Direct cable gland entry (hard wired) PG11 ($\varnothing 4 - \varnothing 10$ mm).

Terminals

The terminal row of the sensor unit is equipped with screw terminals for both internal as well as external cables and wires. The terminals are suitable for wires up to 0.75 mm² (AWG 19).

Power Supply - DC

The *ThinkTop*® is designed to be a part of the PLC's Input/Output (I/O) system. It should be supplied from the same protected power supply as the other I/O devices. The I/O power supply should not be used for other kinds of loads. The unit is reverse polarity and short circuit protected. The power supply must meet the requirements of EN 61131-2.

Supply voltage:	8 - 30 VDC
Supply voltage nominal:	24 VDC (+20%, -15%) - pr. EN 61131-2
Max. ripple:	5% of nominal supply voltage
Supply voltage absolute max:	30 VDC
Supply voltage absolute min.:	8 VDC
Supply current*):	Max. 45 mA (for sensor unit alone) (Excluding current to the solenoids, external proximity switches and the PLC input current.)

*) The initial current during power-on is higher. The actual shape of the current pulse depends on the power supply used. Typical values are 150mA RMS during 13 ms (regulated PS) to 360 mA RMS during 8 ms (unregulated PS).

The fulfilling of the UL requirements in UL508 requires that the unit is supplied by an isolating source complying with the requirements for class 2 power units (UL1310) or class 2 and 3 transformers (UL1585).

Feedback Signals

Output signals from the sensor unit to the connected digital interface (PLC).

Nominal voltage:	Must match the selected type of <i>ThinkTop</i> ®.
Load current:	50 mA typical, 100 mA max.
Voltage drop:	Typical 3 V at 50 mA.

External Sensors

The external sensors are used for seat-lift supervision when seat-lift cannot be internally detected. The sensors get their supply voltage from the terminal row. The output signals from the sensors are connected to two inputs on the terminal row on the internal sensor unit. If the actual setup is set for internal seat-lift, the corresponding external signal is not used, otherwise the external signal logically controls the corresponding feedback to the PLC (Programmable Logic Controller).

Supply voltage:	Must match the selected type of <i>ThinkTop</i> ®.
Supply current:	Max. 15 mA per sensor.
Type of sensor:	DC, only 3-wire sensor PNP.
Cable length:	Max. 3 m.

Polarity

PNP (sourcing) or NPN (sinking) function is selected with a jumper in terminals 12 and 13. Jumper present = PNP. If changing to NPN remove the jumper and make a power recycle. A power recycle is always required when changing this function.

Solenoid valves:

Up to 3 solenoid valves in each unit.

Type	3/2 or 5/2 valve (only possible with one 5/2 valve).
Air supply	300-900 kPa (3-9 bar).
Filtered air, max. particles or dirt	0.01 mm.
Max. flow	180 l/min.
Max. oil content	1.0 ppm.
Max. water content	0.0075 kg/kg air.
Throughput	ø2.5 mm.
Air restriction (throttle function) air inlet/outlet.	
Manual hold override.	
External air tube connection	ø6 mm or 1/4".
Silencer/filter *)	Connection possible via ø6 mm or 1/4".
Nominal voltage	24 VDC.
Nominal power	1.0 W.

**) Filter recommended in tropical regions.

Micro environment demand specifications:

Temperature Working: Storage: Temperature change:	-20°C to +85°C -40°C to +85°C -25°C to +70°C	IEC 68-2-1/2 IEC 68-2-1/2 IEC 68-2-14
Vibration	10-55 Hz, 0.7 mm 55-500 Hz, 10g 3 x 30 min, 1 octave/min	IEC 68-2-6
Drop test		IEC 68-2-32
Humidity Constant humidity: Cyclic humidity: 12 cycles (working)	+40°C, 21 days, 93% R.H. +25°C/+55°C IEC 68-2-30 93% R.H.	IEC68-2-3
Protection class	IP67	IEC 529
Input treshold Voltage/current:	Type 1 input requirements	EN 61131-2
Solenoid signals Isolation voltage	(1000 + 2 x 117) VAC rms/1min	EN 61131-2
EMC Directive	89/336/EEC	EN 50081-1, EN 50082-2
UL approval	8-30 VAC/VDC, Class 2 input, 45 mA max. output	UL508 - E203255

Electrical connection, internal

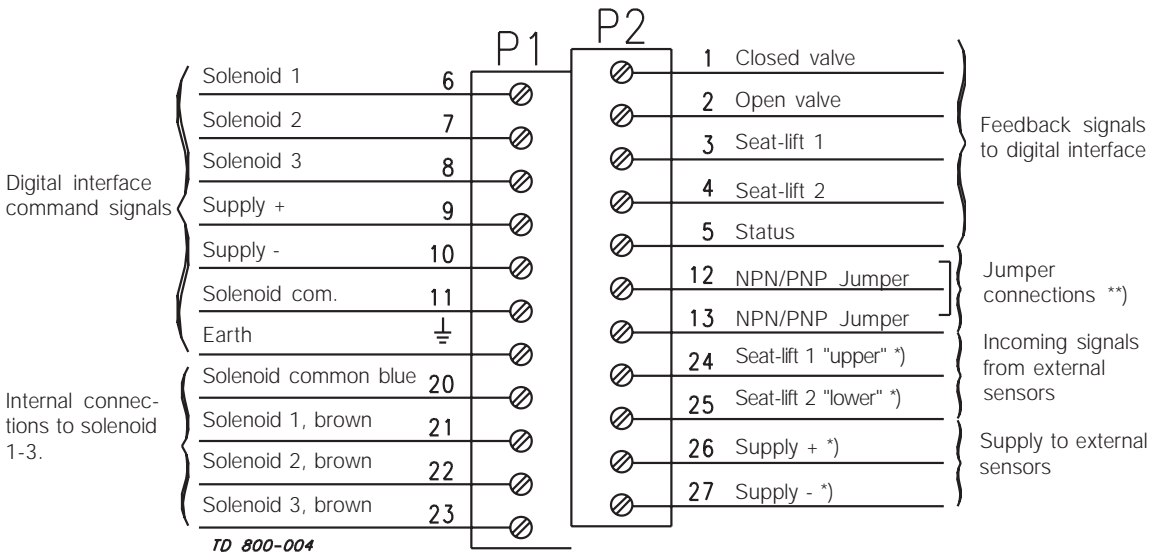

*) **Note!** Terminals 24, 25, 26 and 27 can be used for external seat-lift sensors as well as for any digital input. Always use an external PNP sensor. 2 external signals can be connected, they are associated with feedback signal 3 (seatlift 1) and 4 (seatlift 2). External sensor must always be a 8-30 VDC PNP 3 wire sensor. Connect (-) common on terminal 27, and (+) common on terminal 26. The signals from the external sensors are associated as follows: sensor signal on terminal 24 (seatlift 1) associated with feedback 3 (seatlift 1), and sensor signal on terminal 25 (seatlift 2) associated with feedback 4 (seatlift 2).

) **Note! Jumper present = PNP. If changing the function a power recycle is necessary. The selection NPN/PNP is done by the jumper.

Note! Remember to isolate wires that are not in use.

Example of connecting power supplies

One power supply for sensor system and solenoid valves:

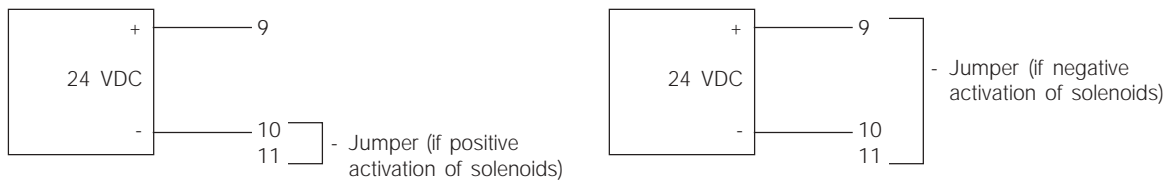

Two power supplies, one for sensor system and one for the solenoid valves:

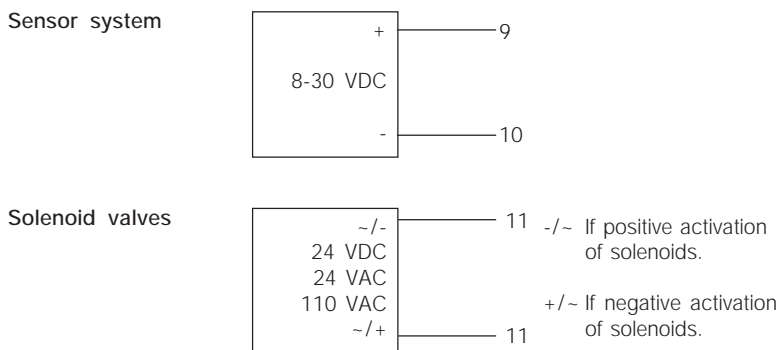

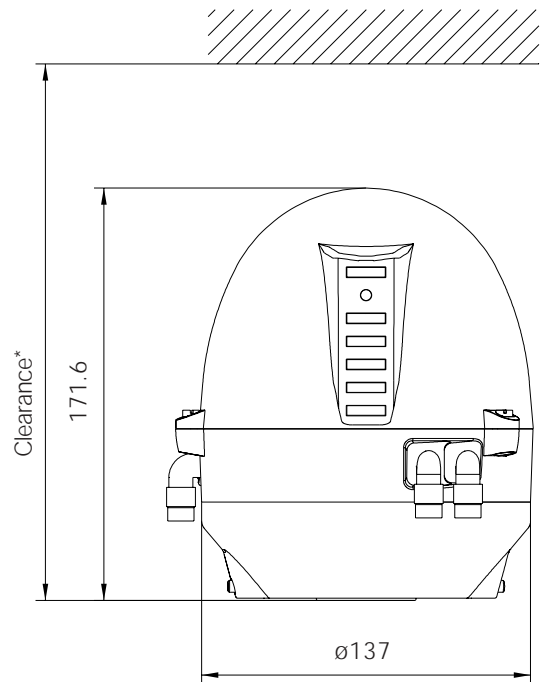
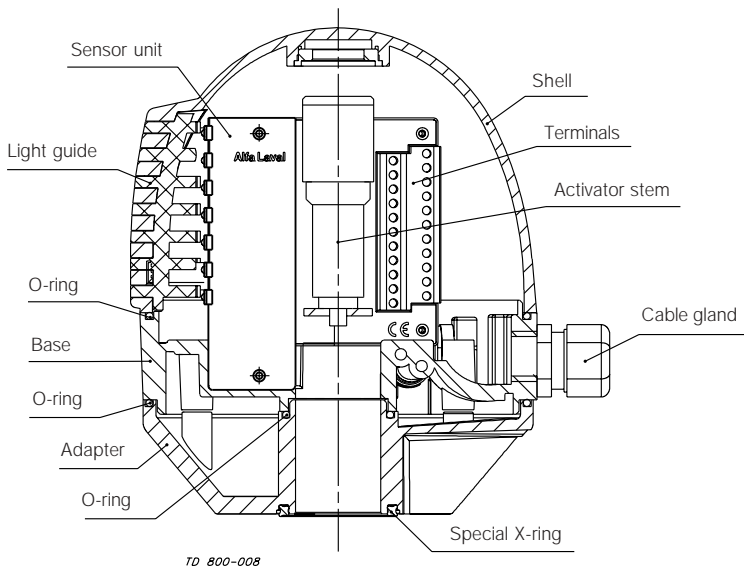

Fig. 3. Dimensions.

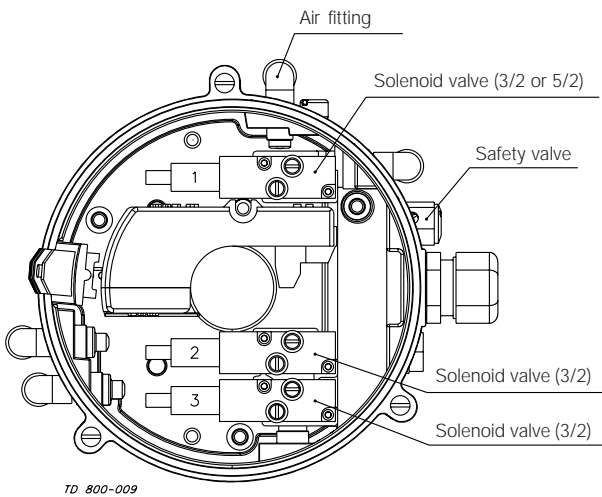

Fig. 2. Basic design, ThinkTop®.

***Note!** This is the basic design. The clearance should be approximately:
 ø225 x 250 mm (SRC NC, SMP-SC/-BC/-TO, *Unique*, Koltek MH, SBV, AMP)
 ø225 x 320 (SRC NO)
 ø225 x 300 (LKB/LKLA-T)

Note! The ThinkTop® for the SMP-EC valve has a longer activator stem which is going through the shell (see Ordering Leaflet).

Options

- Solenoids 24 VAC, 110 VAC.
- 5 m PVC control cable 12 x 0.5 mm², (AWG 20).

Note! Cable not UL approved.

Accessories

- IR keypad.
- External indication bracket for SMP-SC.
- External indication bracket for *Unique*.

Note! For further information: See also IM 70824.

Note! The *ThinkTop*® has Patented Sensor System, Registered Design and Registered Trademark.

Ordering

Please state the following when ordering:

- Digital 8-30 VDC PNP/NPN.
- Number of solenoids (0-3).
- Type of valve (3/2, 5/2).
- Air connection ø6mm or 1/4"
- Please state if SMP-EC or for series 700 valves.