

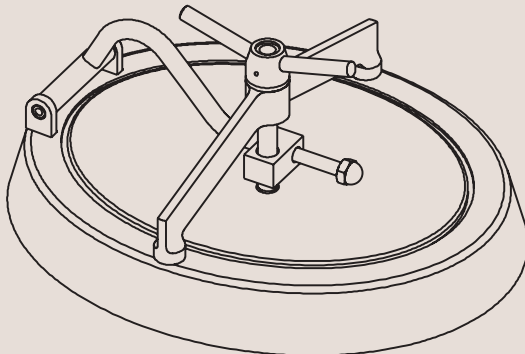

# Instruction Manual

Oval Manhole Covers - LKD-P 450 x 350 for pressure vessels



TD 502-002

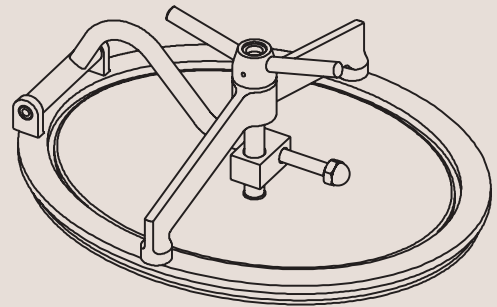



# Declaration of Conformity

---

The designating company

**Alfa Laval**

Company Name

**Albuen 31, DK-6000 Kolding, Denmark**

Address

**+45 79 32 22 00**

Phone No.

hereby declare that

**Oval Manhole Cover**

Denomination

**LKD-P 450 x 350**

Type

**2002**

Year

was manufactured in conformity with PRESSURE EQUIPMENT DIRECTIVE (PED) 97/23/EC OF THE EUROPEAN PARLIAMENT AND OF THE COUNCIL of 29 May 1997 on the approximation of the laws of the Member States concerning pressure equipment.

LKD-P is constructed according to Merkblätter AD 2000 and approved by TÜV Nord e. V. app. No. TK1VA3602 intended for pressure vessels in Category IV and Fluids Group 2.

The Manhole Cover is not pressure tested. It must be tested as a part of the pressure vessel.

**Vice President, R & D**

Title

**Bjarne Søndergaard**

Name

**Alfa Laval**

Company



Signature

---

**Installation:**

1. Remove the seal from the cover.
2. Fit the cover onto the frame (Note the dimensions on the drawing).
3. Adjust the frame to the vessel.
4. Cut a hole fitting the frame in the vessel by using the marking from the frame.
5. Weld the frame onto the vessel.
6. Fit the seal onto the cover.
7. Fit the cover onto the frame.

When welding the cover frame, any possible vessel fatigue should be taken into consideration according to AD B9. The frame must be welded in a way that keeps the sealing surface plane.

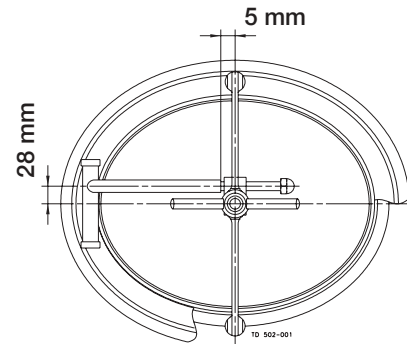

---

**Starting up:**

The cover has not been pressure tested when delivered and must thus be pressure tested together with the vessel.  
Test pressure: 1.43 x working pressure.

Prior to using the cover, make sure that all sealing surfaces are clean and free from burrs.  
The seal must be whole and without any marks.  
Ensure that the clamping nut moves easily and smoothly.  
Check the swinging function.

---

**Operation:**

Prior to closing the cover, ensure that the seal and sealing surface are clean and free from any remains of fluid:

Swing the cover into closed position and adjust it so that it is placed in the centre of the frame. Then turn the bracket to vertical position on the cover and tighten the clamping nut smoothly by hand. Do not use tools when tightening the clamping nut. Max. tightening torque: 32 Nm.

**When the vessel is under pressure, do not overtighten the clamping nut!**

Ensure that the bracket remains in vertical position on the cover before taking the pressure off the vessel in order to keep the cover in its correct place when the vessel is not under pressure.

**Operational Data:**

Max. working pressure is printed on the cover plate.  
Max. working temperature is 100 °C.  
The cover may only be applied for fluids of group 2.

---

**Opening:**

The cover cannot be opened when the vessel is under pressure. Therefore do not try to open it when the vessel is under pressure as the bracket may thus be turned.

When opening the vessel, loosen the clamping nut. Turn the bracket, - now the cover can be swung into the vessel. Then turn the cover and it can now easily be swung out of the vessel.

---

**Maintenance:**

It is important that the clamping nut continuously moves easily and smoothly on the spindle. The thread needs to be lubricated with a suitable lubricant (depending on application) approx. once a year.

Furthermore, the thread needs to be checked for any possible wear. If the clearance between spindle and clamp is too big, the worn part must be replaced.

The bearings in the hinge, too, must be checked and lubricated as needed.

The seal must be checked at least once a year and if damaged, it should be replaced.

---

**Inspection:**

The cover should be inspected together with the vessel and all weldings should visually be inspected every five years.

If the cover shows more than 16,000 cycles with max. pressure, the welding connection between spindle and cover must be NDT tested (capillary test).

---

**Safety Assessment**

LKD-P is constructed as a cover to be welded onto the side of the vessel. The cover is constructed so that it seals the frame on the inside thus causing the cover to remain sealed as pressure is being increased.

The seal is manufactured of a soft elastomer which seals the hole even if the surface of the frame is slightly unplane. Due to the construction it is not possible to open the cover when the vessel is under pressure.

When opening the cover, do not totally unscrew the clamping nut as that will cause the cover to fall to the bottom of the vessel when the cover is swung into the vessel.

A sensor (electrical or mechanical) can be installed on the cover. This sensor will warn of an open cover before any fluid is filled into the vessel.

Thus applying the cover does not involve any danger if only the cover has been correctly closed and the bracket has been thoroughly tightened to the frame.

---

**How to contact Alfa Laval**

Contact details for all countries are continually updated on our website. Please visit [www.alfalaval.com](http://www.alfalaval.com) to access the information direct.