

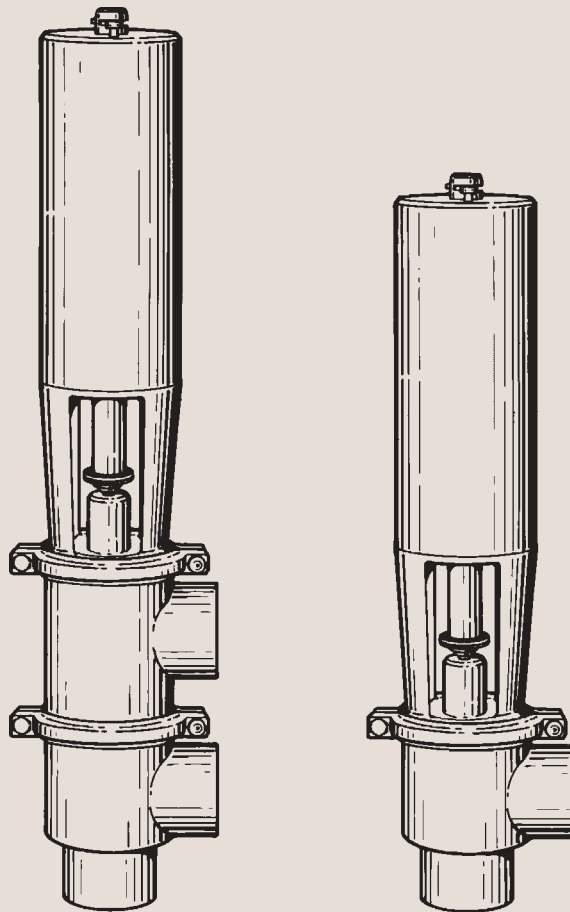

# Instruction Manual

SRC-LS Sanitary Remote-controlled Long-Stroke Valve



# Declaration of Conformity

## The designating company

**Alfa Laval**

Company Name

**6000 Kolding**

Address

**+45 79 32 22 00**

Phone No.

hereby declare that

**Sanitary Remote-Controlled Valve**

Denomination

**SRC-LS**

Type

Year

Was manufactured in conformity with the provisions in the COUNCIL DIRECTIVE of 14 June 1989 on mutual approximation of the laws of the Member States on the safety of machines (89/392/EEC as amended by directives 91/368/EEC and 93/44/EEC) with special reference to Annex 1 of the directive on essential safety and health requirements in relation to the construction and manufacture of machines.

**Bjarne Søndergaard**

Name

**Vice President, R & D**

Title

**Alfa Laval**

Company

*B. Søndergaard*

Signature

**Designation**

**CE**

# Table of contents

*This manual is divided into main sections. - See below.*

## **Safety**

1. Important information .....	2
2. Warning signs .....	2
3. Safety precautions .....	3

## **Installation**

1. Unpacking/Delivery .....	4
2. General installation .....	5
3. Welding .....	6

## **Operation**

1. Operation .....	7
2. Fault finding .....	8
3. Recommended cleaning .....	9

## **Maintenance**

1. General maintenance .....	10
2. Dismantling of valve .....	12
3. Assembly of valve .....	13
4. Dismantling of actuator .....	14
5. Assembly of actuator .....	15

## **Technical data**

1. Technical data .....	16
-------------------------	----

## **Drawings/Parts list**

1. Parts list .....	18+20+22+24
2. Exploded drawing .....	19+23
3. Drawings .....	21+25

# Safety

Unsafe practices and other important information are emphasized in this manual.

Warnings are emphasized by means of special signs.

## 1. Important information

Always read the manual before using the valve!

2

- WARNING!** : Indicates that special procedures **must** be followed to avoid severe personal injury.
- CAUTION!** : Indicates that special procedures **must** be followed to avoid damage to the valve.
- NOTE!** : Indicates important information to simplify practices or to make them clearer.

---

## 2. Warning signs



: General warning.



: Caustic agents.

All warnings in the manual are summarized on this page.

Pay special attention to the instructions below so that severe personal injury or damage to the valve are avoided.

## 3. Safety precautions

### Installation:



- : - **Always** observe the technical data (see page 16).
- **Always** release compressed air after use.



- : **Never** touch the clip assembly or the actuator piston rod if the actuator is supplied with compressed air.

### Operation:



- : - **Always** observe the technical data (see page 16).
- **Always** release compressed air after use.



- : **Never** touch the valve or the pipelines when processing hot liquids or when sterilizing.



- : **Never** touch the clip assembly or the actuator piston rod if the actuator is supplied with compressed air.



- : **Always** handle lye and acid with great care.

### Maintenance:



- : - **Always** observe the technical data (see page 16).
- **Always** release compressed air after use.



- : - The valve must **never** be hot when serviced.
- The valve and the pipelines must **never** be pressurised when the valve is serviced.



- : **Never** stick your fingers through the valve ports if the actuator is supplied with compressed air.



- : **Never** touch the clip assembly or the actuator piston rod if the actuator is supplied with compressed air.

# Installation

The instruction manual is part of the delivery.  
Study the instructions carefully.  
The items refer to the drawings and the parts list on pages 18-25.

## 1. Unpacking/Delivery

**1**

### NOTE!

We cannot be held responsible for incorrect unpacking.

### Check the delivery:

1. Complete valve, stop valve or change-over valve (see 2 and 3).
2. Delivery note.
3. Instruction Manual.

The valve is supplied as separate parts as standard (for welding).

The valve is assembled before delivery, if it is supplied with fittings.

**2**

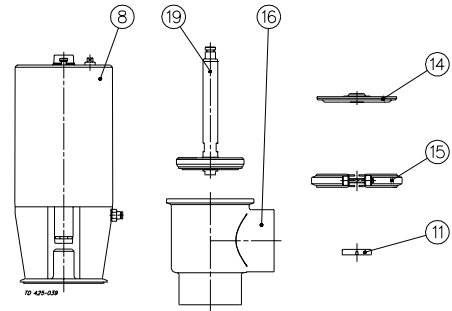

### Delivery of stop valve:

1. Complete actuator with bonnet (8).
2. Clip assembly (11).
3. Lip seal (14).
4. Clamp (15).
5. Valve plug (19).
6. Valve body (16).

**3**

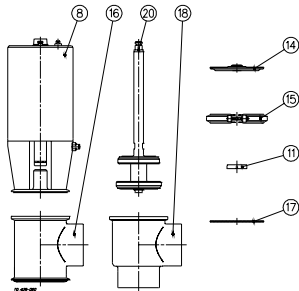

### Delivery of change-over valve:

1. Complete actuator with bonnet (8).
2. Clip assembly (11).
3. Lip seal (14).
4. Two clamps (15).
5. Valve plug (20).
6. Two valve bodies (16, 18).
7. Valve body seal ring (17).

**4**

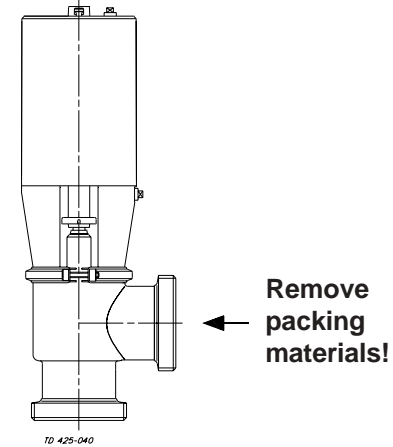

Clean the valve/valve parts from possible packing materials.

**5**

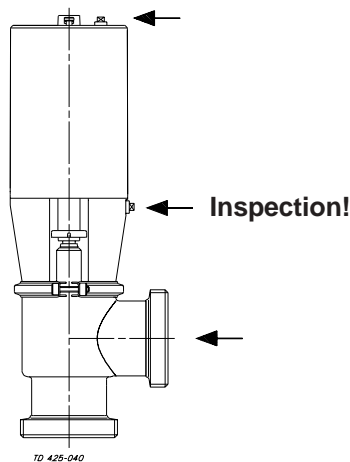

Inspect the valve/valve parts for visible transport damage.

**6**

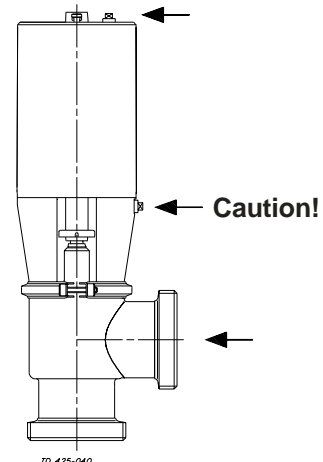

Avoid damaging the valve/valve parts.

Study the instructions carefully and pay special attention to the warnings!  
The valve has welding ends as standard but can also be supplied with fittings.

## 2. General installation

1



- **Always** observe the technical data (see page 16).
- **Always** release compressed air after use.

**NOTE!**

We cannot be held responsible for incorrect installation.

2

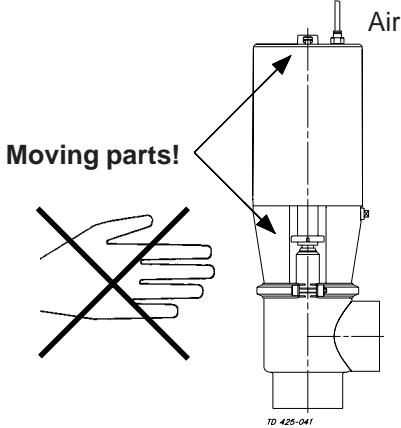

**Never** touch the clip assembly or the actuator piston rod if the actuator is supplied with compressed air.

3

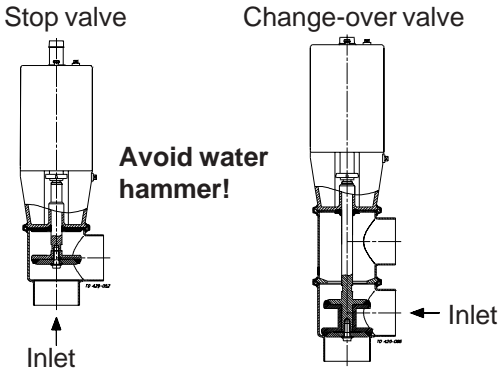

It is recommended to install the valve so that:

- The actuator is not turned downwards as the valve will then not be drained.
- The flow is against the closing direction to avoid water hammer.

4

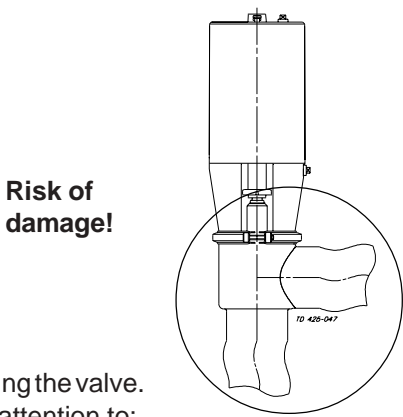

Avoid stressing the valve. Pay special attention to:

- Vibrations.
- Thermal expansion of the tubes.
- Excessive welding.
- Overloading of the pipelines.

5

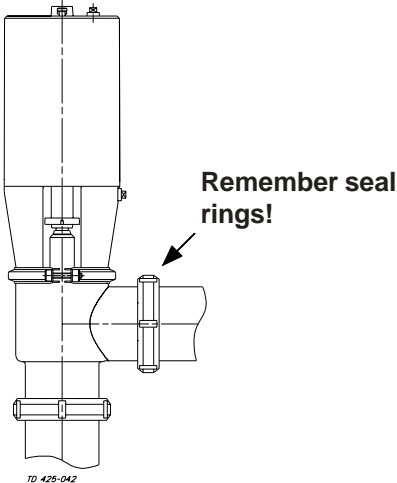

**Fittings:**  
Ensure that the connections are tight.

6

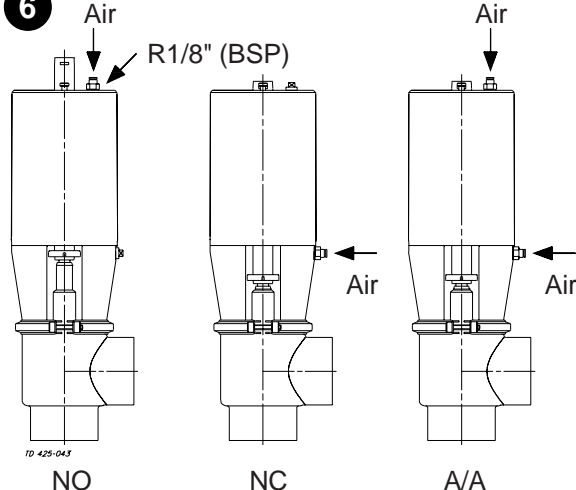

**Air connection:**

# Installation

Study the instructions carefully.  
The valve is supplied as separate parts to facilitate the welding.

The items refer to the drawings and the parts list on pages 18-25.  
Check the valve for smooth operation after welding.

## 3. Welding

**1**

Always weld the valve so that the valve body seal ring can be replaced (change-over valve).

Maintain the minimum clearances (A and B) so that the lower valve plug (change-over valve) and the actuator with the internal parts can be removed.

Valve size	A (mm)	B <sub>1</sub> (mm)	B <sub>2</sub> (mm)
DN50/51 mm	190	600	780
DN65/63.5 mm	210	730	910
DN80/76 mm	235	780	960
DN100/101.6 mm	270	780	960

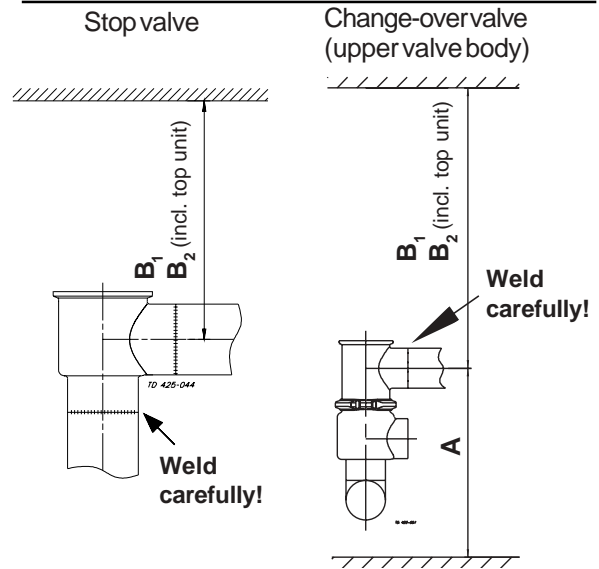

**2**

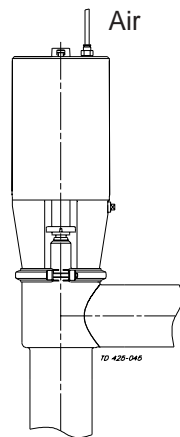

**Stop valve:**  
Assemble the valve in accordance with instructions 2-5 on page 13.  
**Pay special attention to the warnings!**

**3**

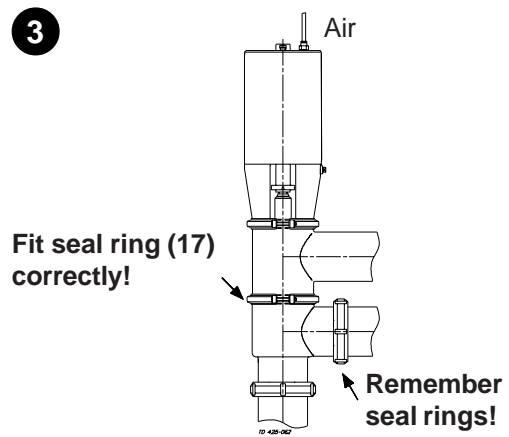

**Change-over valve:**  
Assemble the valve in accordance with instructions 2-6 on page 13.  
**Pay special attention to the warnings!**

**4**

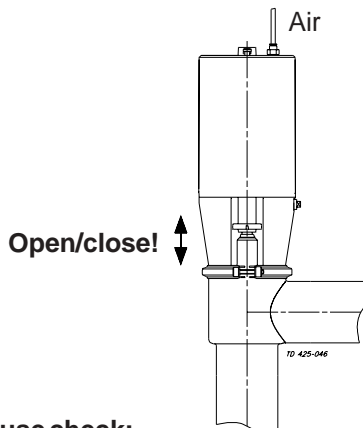

**Pre-use check:**

1. Supply compressed air to the actuator.
2. Open and close the valve several times to ensure that it operates smoothly.

**Pay special attention to the warnings!**



Study the instructions carefully and pay special attention to the warnings!  
Ensure that the valve operates smoothly.

The items refer to the drawings and the parts list on pages 18-25.

## 1. Operation

1



- **Always** observe the technical data (see page 16).
- **Always** release compressed air after use.

### NOTE!

We cannot be held responsible for incorrect operation.

2

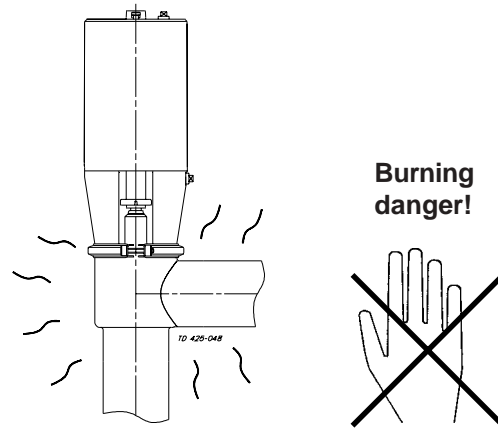

**Never** touch the valve or the pipelines when processing hot liquids or when sterilizing.

3

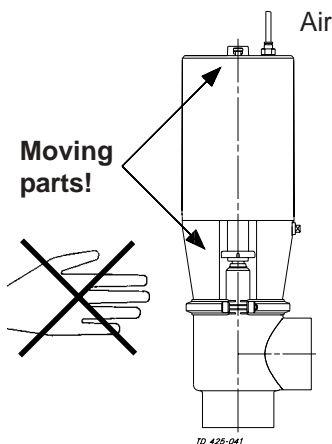

**Never** touch the clip assembly or the actuator piston rod if the actuator is supplied with compressed air.

4

Stop valve      Change-over valve

**Lubricate if necessary!**

(see page 11).

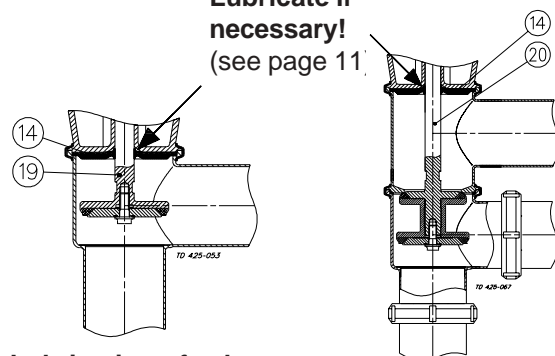

### Lubrication of valve:

1. Ensure smooth movement between lip seal (14) and plug stem (19, 20).
2. Lubricate with silicone oil/grease if necessary.

5

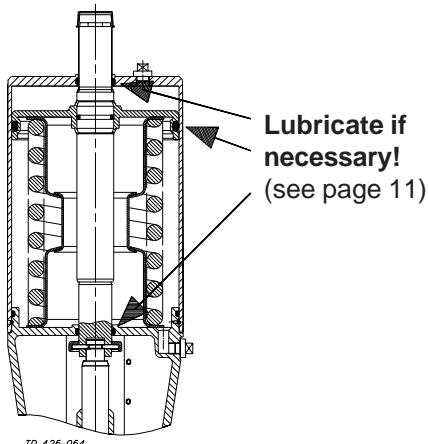

### Lubrication of actuator

1. Ensure smooth movement of the actuator (the actuator is lubricated before delivery).
2. Lubricate with grease if necessary.

Pay attention to possible faults.

Study the instructions carefully.

The items refer to the drawings and the parts list on pages 18-25.

## 2. Fault finding

8

### NOTE!

Study the maintenance instructions carefully before replacing worn parts. - See page 10!

Problem	Cause/result	Repair
The valve plug jerks	The sealings seize	Lubricate: - O-rings (2) - O-ring (5) and the inside of cylinder (3) - Lip seal (14)
Product leakage at stem and/or clamp	Worn/product affected lip seal (14) and/or seal ring (17)	- Replace the seals - Select a different rubber grade
Product leakage (closed valve)	- Worn/product affected plug seal ring - Loose plug parts (vibrations) - Product deposits on the seat and/or plug	- Replace the seal ring - Select a different rubber grade - Tighten the loose parts - Frequent cleaning
Product leakage (too high pressure or too small actuator)	- Worn actuator O-rings - Too small actuator or	- Replace the O-rings - Use auxiliary air on the spring side (NOT-element)
Water hammer	The flow direction is the same as the closing direction	- The flow direction should be against the closing direction - Use auxiliary air on the spring side (NOT-element)
The valve does not open/close	- Faulty clip assembly (11) - The pressure on the plug plug is too high	- Replace the clip assembly - Reduce the pressure

The valve is designed for cleaning in place (CIP).  
CIP = Cleaning In Place.

Study the instructions carefully and pay special attention to the warnings!  
NaOH = Caustic Soda.  
HNO<sub>3</sub> = Nitric acid.

## 3. Recommended cleaning

### 1 Caustic danger!



Always use rubber gloves!



Always use protective goggles!



Always handle lye and acid with great care.

### 3 Stop valve

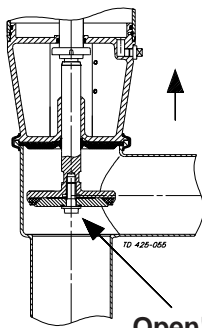

Open!

### Change-over valve

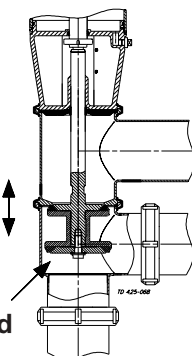

Lift and lower momentarily (flip)!

Clean the plug and the seats correctly.  
Pay special attention to the warnings!

### 5

- Avoid excessive concentration of the cleaning agent  
⇒ **Dose gradually!**
- Adjust the cleaning flow to the process  
⇒ **Milk sterilization/viscous liquids**  
⇒ **Increase the cleaning flow!**
- Always** rinse well with clean water after the cleaning.

### 2

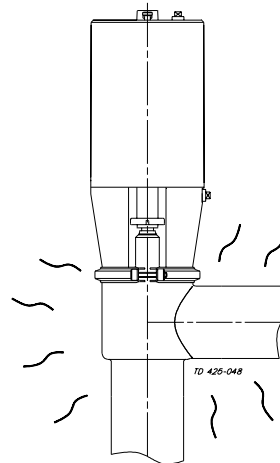

Burning danger!

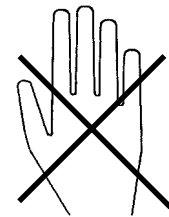

Never touch the valve or the pipelines when sterilizing.

### 4

#### Examples of cleaning agents:

Use clean water, free from chlorides.

- 1% by weight NaOH at 70°C.

1 kg NaOH	+	100 l water	= Cleaning agent.
-----------	---	-------------	-------------------

2.2 l 33% NaOH	+	100 l water	= Cleaning agent.
----------------	---	-------------	-------------------

- 0.5% by weight HNO<sub>3</sub> at 70°C.

0.7 l 53% HNO <sub>3</sub>	+	100 l water	= Cleaning agent.
----------------------------	---	-------------	-------------------

### 6

#### NOTE!

The cleaning agents must be stored/discharged in accordance with current rules/directives.

# Maintenance

10

Maintain the valve carefully.  
Study the instructions carefully and pay special attention to the warnings!

Always keep spare rubber seals and lip seals in stock.

## 1. General maintenance

1



- **Always** observe the technical data (see page 16).
- **Always** release the compressed air after use.

### NOTE!

All scrap must be stored/discharged in accordance with current rules/directives.

2

Burning danger!

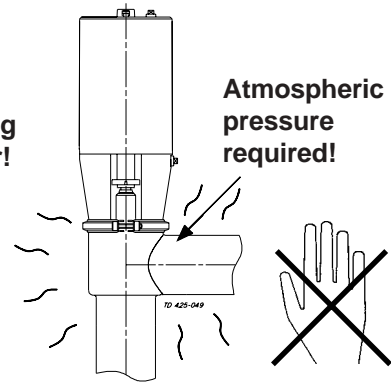

- The valve must **never** be hot when serviced.
- The valve and the pipelines must **never** be pressurised when the valve is serviced.

3

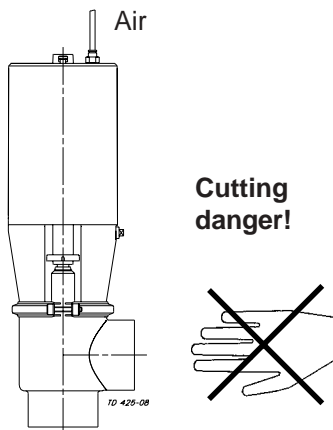

**Never** stick your fingers through the valve ports if the actuator is supplied with compressed air.

4

Moving parts!

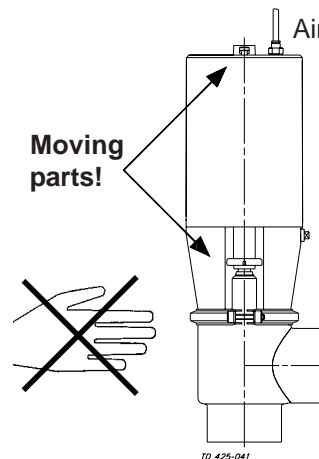

**Never** touch the clip assembly or the actuator piston rod if the actuator is supplied with compressed air.

## Ordering spare parts

- Contact the Sales Department.
- Order from the Spare Parts List.

Recommended spare parts: Service kits (see Spare Parts List).

Maintain the valve carefully.  
Study the instructions carefully.

Always keep spare rubber seals and lip seals stock.  
Check the valve for smooth operation after service.

## 1. General maintenance

	Valve rubber seals	Valve lip seal	Actuator rubber seals
Preventive maintenance	<b>Replace after 12 months</b>	Replace when replacing the rubber seals	<b>Replace after 5 years</b>
Maintenance after leakage (leakage normally starts slowly)	<b>Replace at the end of the day</b>	Replace when replacing the rubber seals	<b>Replace when possible</b>
Planned maintenance	<ul style="list-style-type: none"> <li>- Regular inspection for leakage and smooth operation</li> <li>- Keep a record of the valve</li> <li>- Use the statistics for planning of inspections</li> </ul> <b>Replace after leakage</b>	Replace when replacing the rubber seals	<ul style="list-style-type: none"> <li>- Regular inspection for leakage and smooth operation</li> <li>- Keep a record of the actuator</li> <li>- Use the statistics for planning of inspections</li> </ul> Replace after leakage
Lubrication (USDA H1 approved oil/grease)	<b>Before fitting</b> Silicone oil or silicone grease	<b>Before fitting</b> Silicone oil or silicone grease	<b>Before fitting</b> Grease

### Pre-use check:

1. Supply compressed air to the actuator.
2. Open and close the valve several times to ensure that it operates smoothly.

**Pay special attention to the warnings!**

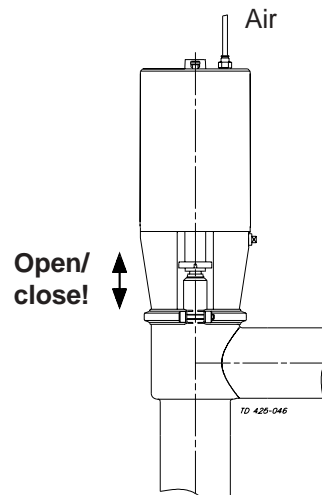

# Maintenance

Study the instructions carefully.  
The items refer to the drawings and the parts list on pages 18-25.

Handle scrap correctly.  
NC = Normally closed.  
NO = Normally open.  
A/A = Air/air activated.

## 2. Dismantling of valve

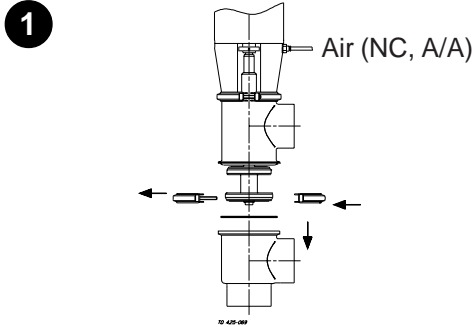

### Change-over valve:

1. Supply compressed air to the actuator.
2. Remove lower clamp (15).
3. Remove lower valve body (18).
4. Remove seal ring (17).
5. Release compressed air.

**Pay special attention to the warnings!**

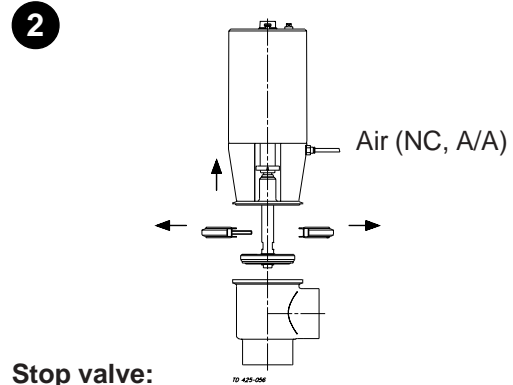

### Stop valve:

1. Supply compressed air to the actuator.
2. Remove clamp (15).
3. Remove the actuator.
4. Release compressed air.

**Pay special attention to the warnings!**

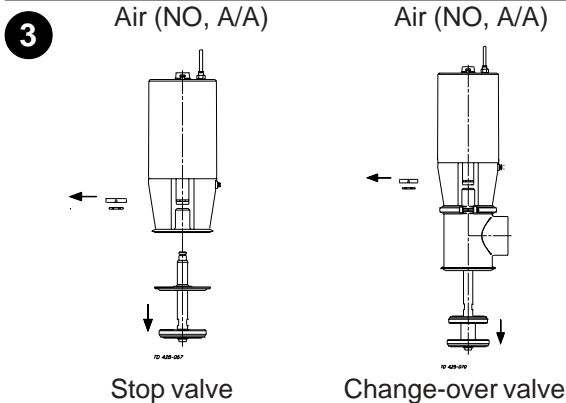

1. Supply compressed air to the actuator.
2. Remove clip assembly (11).
3. Remove valve plug (19, 20).
4. Release compressed air.

**Pay special attention to the warnings!**

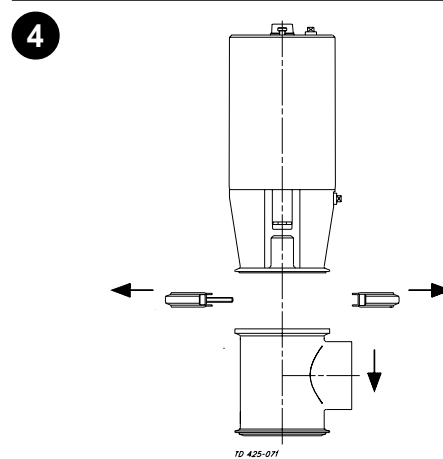

### Change-over valve:

1. Remove upper clamp (15).
2. Remove upper valve body (16).

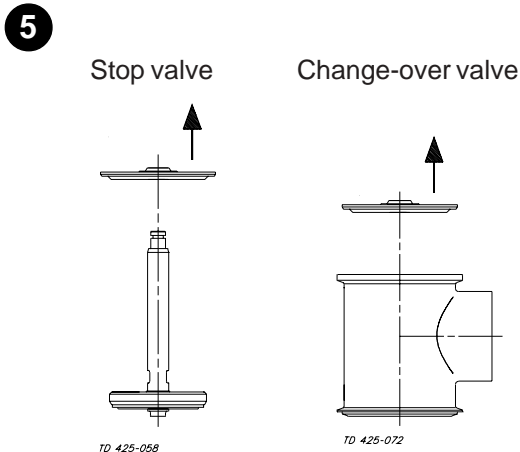

Remove lip seal (14).

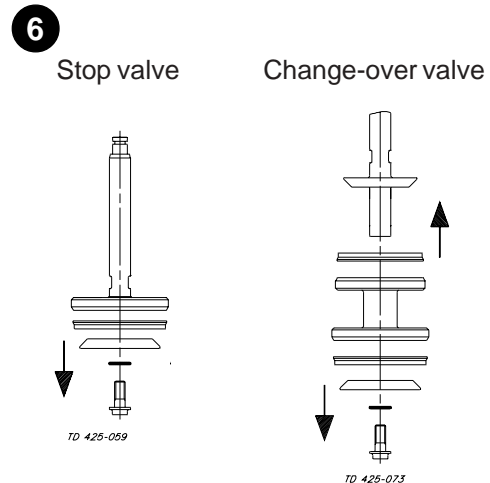

1. Remove screw (19h, 20h).
2. Dismantle the complete valve plug.

Study the instructions carefully.  
The items refer to the drawings and the parts list on pages 18-25.

Lubricate the rubber seals and the lip seal before fitting them.  
Lip seal (14) can be replaced by a special stem seal.

## 3. Assembly of valve

### 1 Stop valve Change-over valve

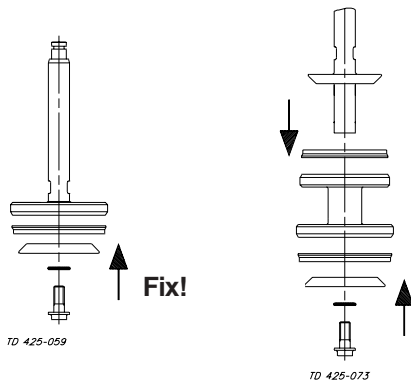

1. Assemble the complete valve plug.
2. Fix screw (19h, 20h) by using loctite or something similar.

### 2 Stop valve Change-over valve

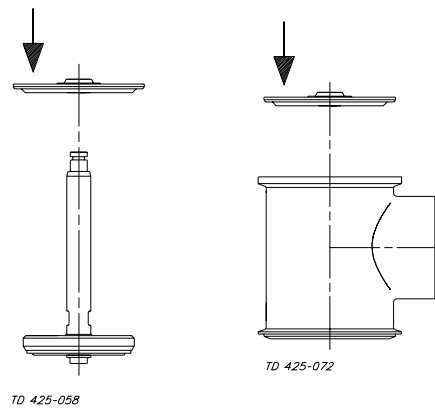

Fit lip seal (14).

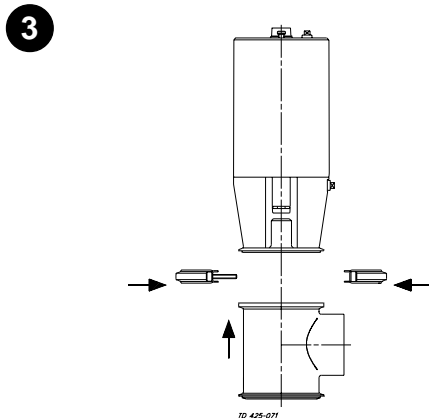

#### Change-over valve:

1. Assemble upper valve body (16) and the actuator.
2. Fit and tighten upper clamp (15).

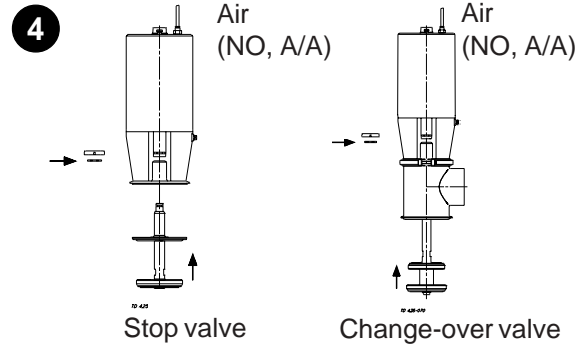

1. Fit the plastic ring of clip assembly (11) on the actuator piston rod.
2. Supply compressed air to the actuator.
3. Fit valve plug (19,20).
4. Fit and assemble clip assembly (11).
5. Release compressed air.

**Pay special attention to the warnings!**

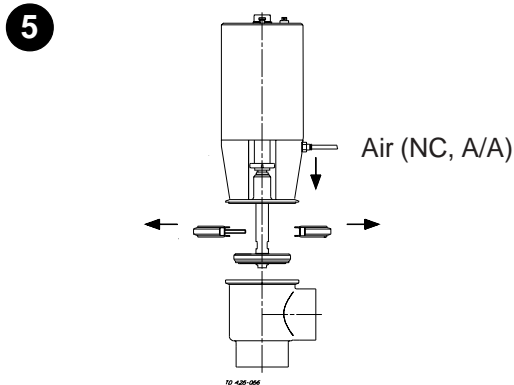

#### Stop valve:

1. Supply compressed air to the actuator.
2. Fit the actuator.
3. Fit and tighten clamp (15).
4. Release compressed air.

**Pay special attention to the warnings!**

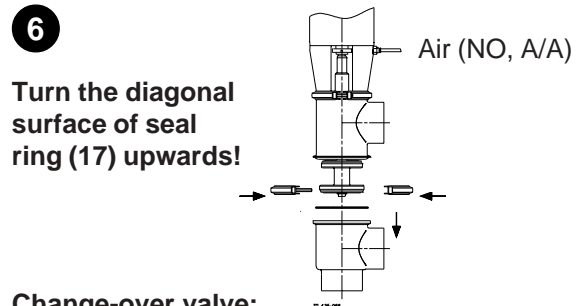

#### Change-over valve:

1. Fit seal ring (17) correctly in lower valve body (18).
2. Supply compressed air to the actuator
3. Assemble lower and upper valve bodies (16, 18).
4. Fit and tighten lower clamp (15).
5. Release compressed air.

**Pay special attention to the warnings!**

# Maintenance

14

Study the instructions carefully.  
The items refer to the drawings and the parts list on pages 18-25.

Handle scrap correctly.  
A/A = Air/air activated.

## 4. Dismantling of actuator

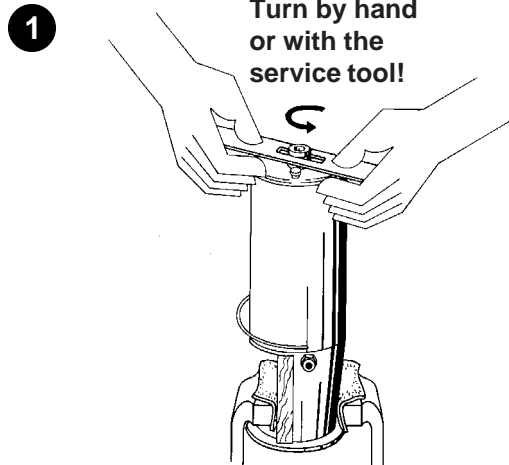

1. Turn cylinder (3).
2. Remove lock wire (4).

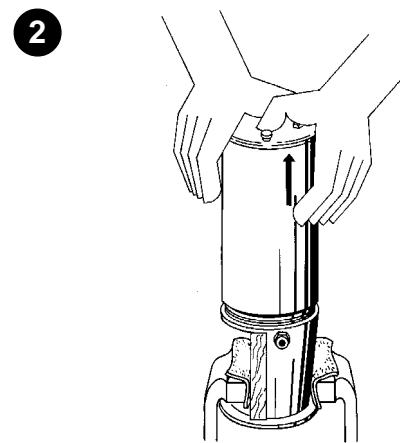

1. Remove cylinder (3).
2. Remove O-rings (2, 7) from bonnet (8).

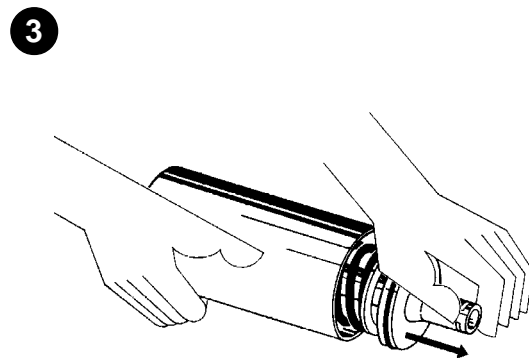

1. Remove piston (6) and spring assembly (10).
2. Remove O-ring (5) from the piston.
3. Remove O-ring (2) from cylinder (3).

### NOTE!

The A/A actuator has no spring assembly.

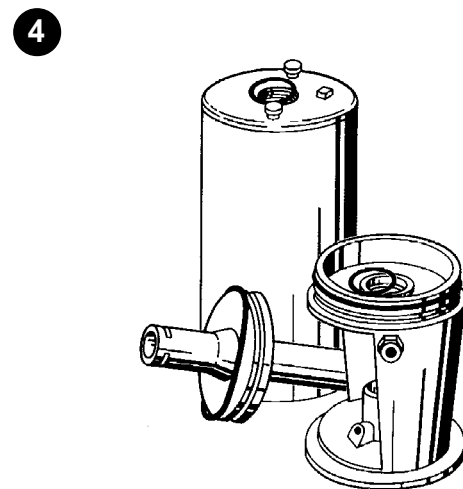

Replace the rubber seals.



Study the instructions carefully.  
The items refer to the drawings and the parts list on pages 18-25.

Lubricate the rubber seals before fitting them.  
A/A = Air/air activated.

## 5. Assembly of actuator

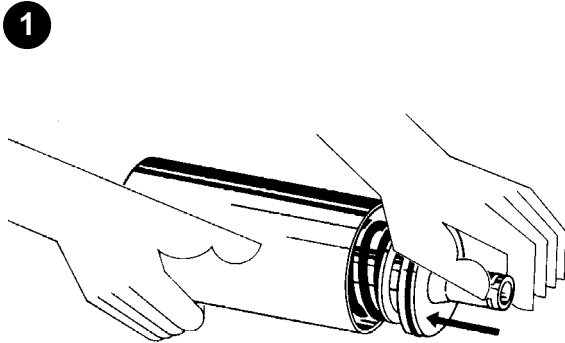

1. Fit O-ring (2) in cylinder (3).
2. Fit O-ring (5) on piston (6).
3. Fit the piston and spring assembly (10).

### NOTE!

The A/A actuator has no spring assembly.

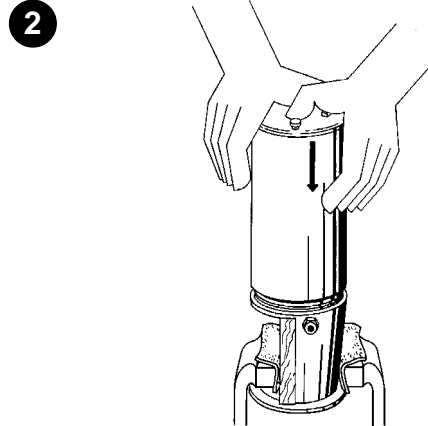

1. Fit O-rings (2, 7) in bonnet (8).
2. Fit cylinder (3).

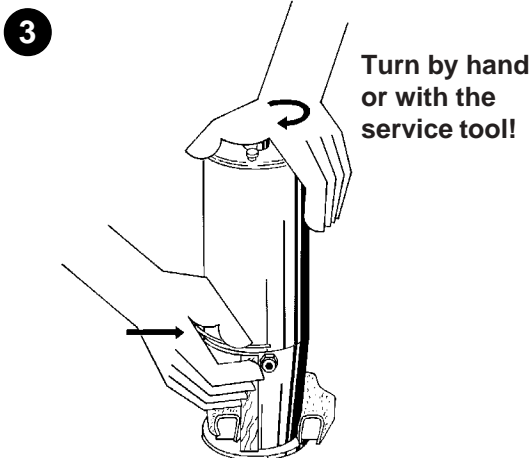

1. Fit lock wire (4) through the slot in cylinder (3) into the hole in bonnet (8).
2. Turn the cylinder 360° (see 4).

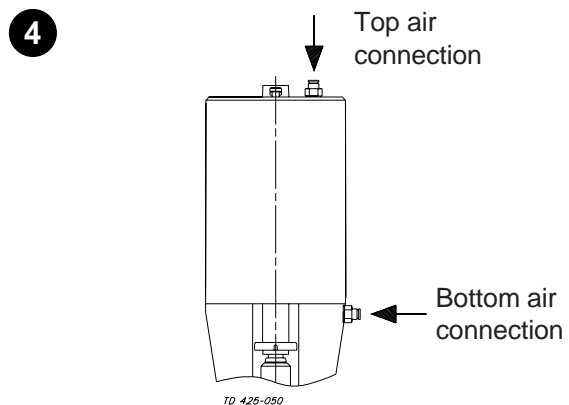

### NOTE!

It is recommended to turn cylinder (3) further 180° in relation to bonnet (8) so that the top and bottom air connections are fixed on the same side.

# Technical data

*It is important to observe the technical data during installation, operation and maintenance.*

*Inform the personnel about the technical data.*

## 1. Technical data

16

---

### Data - valve/actuator

---

Max. product pressure .....	1000kPa(10bar)
Min. product pressure .....	Full vacuum
Temperature range .....	-10°C to + 140°C (EPDM)
Air pressure, actuator .....	500 to 700kPa (5 to 7 bar)

---

### Materials - valve/actuator

---

Product wetted steel parts .....	AISI 316L
Other steel parts .....	AISI 304
Plug stem .....	AISI 316 with hard chrome plated stem surface
Product wetted seals .....	EPDM (standard)
Other seals .....	Nitrile (NBR)
Alternative product wetted seals .....	Nitrile (NBR) and Viton (FPM)
Finish .....	Semi bright



# Drawing/Parts list

The drawings and the parts list include all items.  
NO = Normally open.  
NC = Normally closed.

The items are identical with the items in the Spare Parts List.  
When ordering spare parts, please use the Spare Parts List!

## Parts list SRC-LS - stop valve

18

Item	Qty.	Denomination
1	1	End cap
2Δ	2	O-ring
3	1	Cylinder
4Δ	1	Lock wire
5Δ	1	O-ring
6	1	Piston
7Δ	1	O-ring
8	1	Bonnet
9◆	2	Plug
10◆	1	Spring assembly
11Δ	1	Clip assembly
14Δ	1	Lip seal
15	2	Clamp half with screw (stop valve)
	4	Clamp half with screw (Change-over valve)
16	1	Valve body, upper
17Δ	1	Valve body seal ring
18	1	Valve body
19	1	Valve plug, single, complete
19a	1	Stem
19eΔ	1	Seal ring
19f	1	Washer
19gΔ	1	O-ring
19h	1	Screw
20	1	Valve plug, double, complete
20b	1	Stem
20c	1	Seal ring, upper
20d	1	Middle piece
20e	1	Seal ring, lower
20f	1	Washer
20g	1	O-ring
20h	1	Screw

Δ : Service kit - EPDM, NBR, FPM  
(See Spare Parts List)

◆ : Only for NO - and NC actuators.

This page shows an exploded drawing of SRC-LS, stop valve.

The drawing includes all items of the valve. They are identical with the items in the Spare Parts List

## Exploded drawing

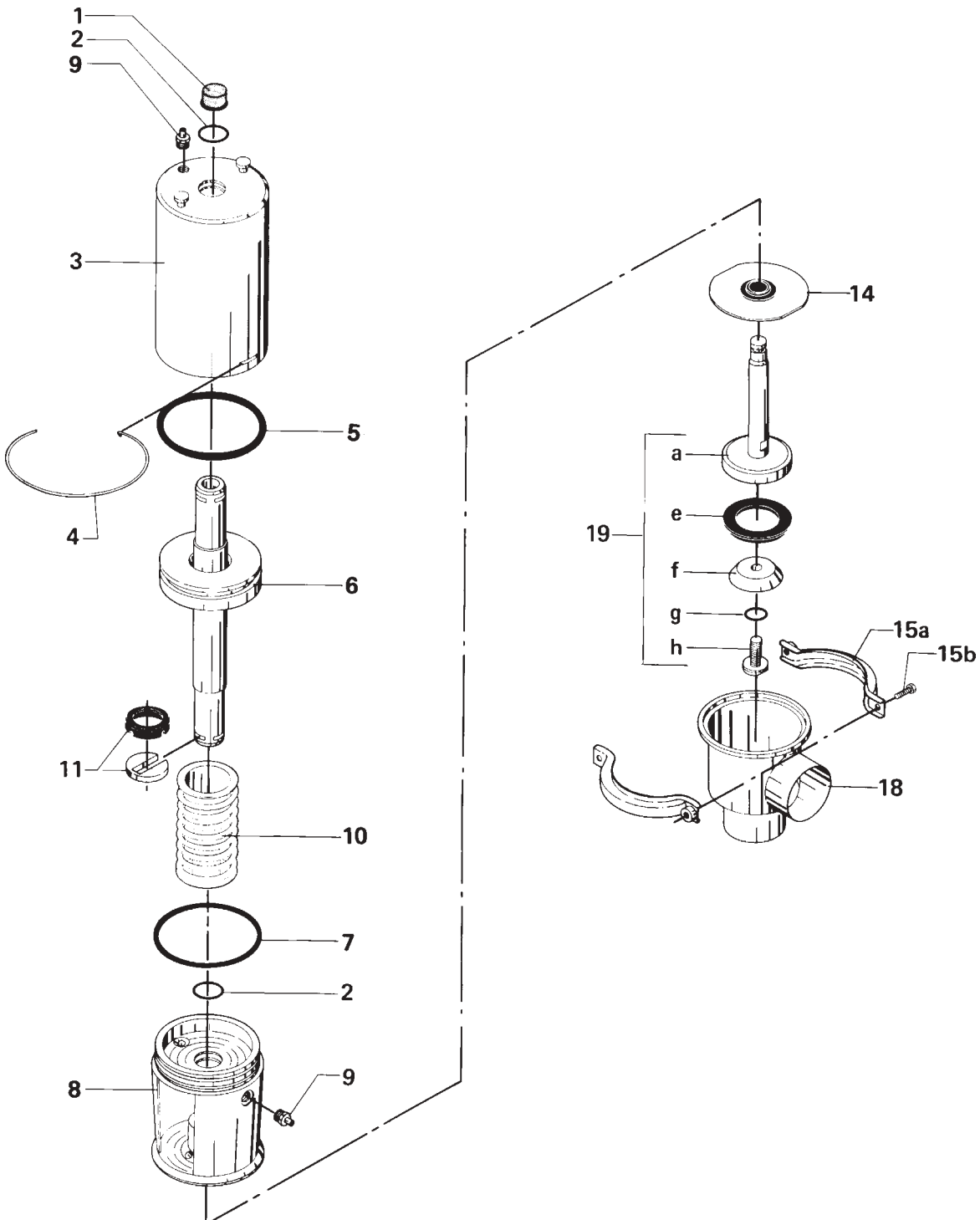

## Drawing/Parts list

The drawings and the parts list include all items.  
NO = Normally open.  
NC = Normally closed.

The items are identical with the items in the Spare Parts List.  
When ordering spare parts, please use the Spare Parts List!

### Parts list SRC-LS - stop valve

20

Item	Qty.	Denomination
1	1	End cap
2Δ	2	O-ring
3	1	Cylinder
4Δ	1	Lock wire
5Δ	1	O-ring
6	1	Piston
7Δ	1	O-ring
8	1	Bonnet
9◆	2	Plug
10◆	1	Spring assembly
11Δ	1	Clip assembly
14Δ	1	Lip seal
15	2	Clamp half with screw (stop valve)
	4	Clamp half with screw (Change-over valve)
16	1	Valve body, upper
17Δ	1	Valve body seal ring
18	1	Valve body
19	1	Valve plug, single, complete
19a	1	Stem
19eΔ	1	Seal ring
19f	1	Washer
19gΔ	1	O-ring
19h	1	Screw
20	1	Valve plug, double, complete
20b	1	Stem
20c	1	Seal ring, upper
20d	1	Middle piece
20e	1	Seal ring, lower
20f	1	Washer
20g	1	O-ring
20h	1	Screw

Δ : Service kit - EPDM, NBR, FPM  
(See Spare Parts List)

◆ : Only for NO - and NC actuators.

The drawings below show SRC-LS, stop valve.

The items refer to the parts list on the opposite part of the page.

## Drawings

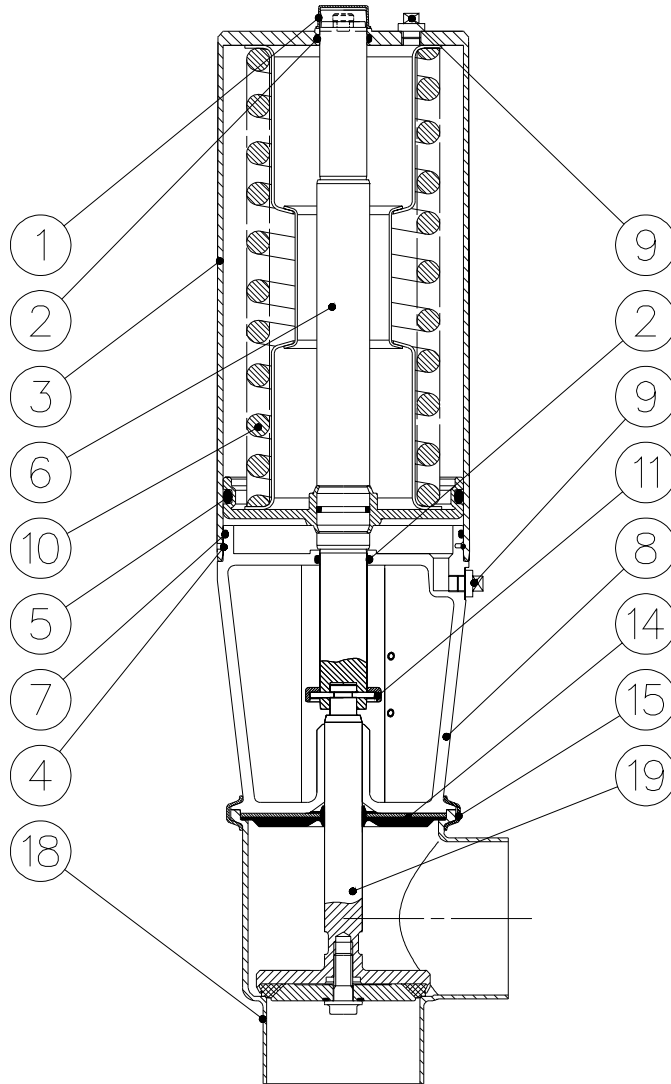

TD 426-022

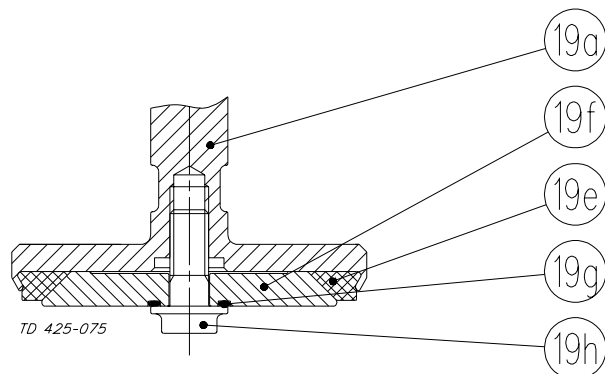

TD 425-075

## Drawing/Parts list

The drawings and the parts list include all items.  
NO = Normally open.  
NC = Normally closed.

The items are identical with the items in the Spare Parts List.  
When ordering spare parts, please use the Spare Parts List!

### Parts list SRC-LS - change-over valve

22

Item	Qty.	Denomination
1	1	End cap
2Δ	2	O-ring
3	1	Cylinder
4Δ	1	Lock wire
5Δ	1	O-ring
6	1	Piston
7Δ	1	O-ring
8	1	Bonnet
9◆	2	Plug
10◆	1	Spring assembly
11Δ	1	Clip assembly
14Δ	1	Lip seal
15	2	Clamp half with screw (stop valve)
	4	Clamp half with screw (Change-over valve)
16	1	Valve body, upper
17Δ	1	Valve body seal ring
18	1	Valve body
19	1	Valve plug, single, complete
19a	1	Stem
19eΔ	1	Seal ring
19f	1	Washer
19gΔ	1	O-ring
19h	1	Screw
20	1	Valve plug, double, complete
20b	1	Stem
20c	1	Seal ring, upper
20d	1	Middle piece
20e	1	Seal ring, lower
20f	1	Washer
20g	1	O-ring
20h	1	Screw

Δ : Service kit - EPDM, NBR, FPM  
(See Spare Parts List)

◆ : Only for NO - and NC actuators.



This page shows an exploded drawing of SRC-LS, change-over valve.

The drawing includes all items of the valve. They are identical with the items in the Spare Parts List.

## Exploded drawing

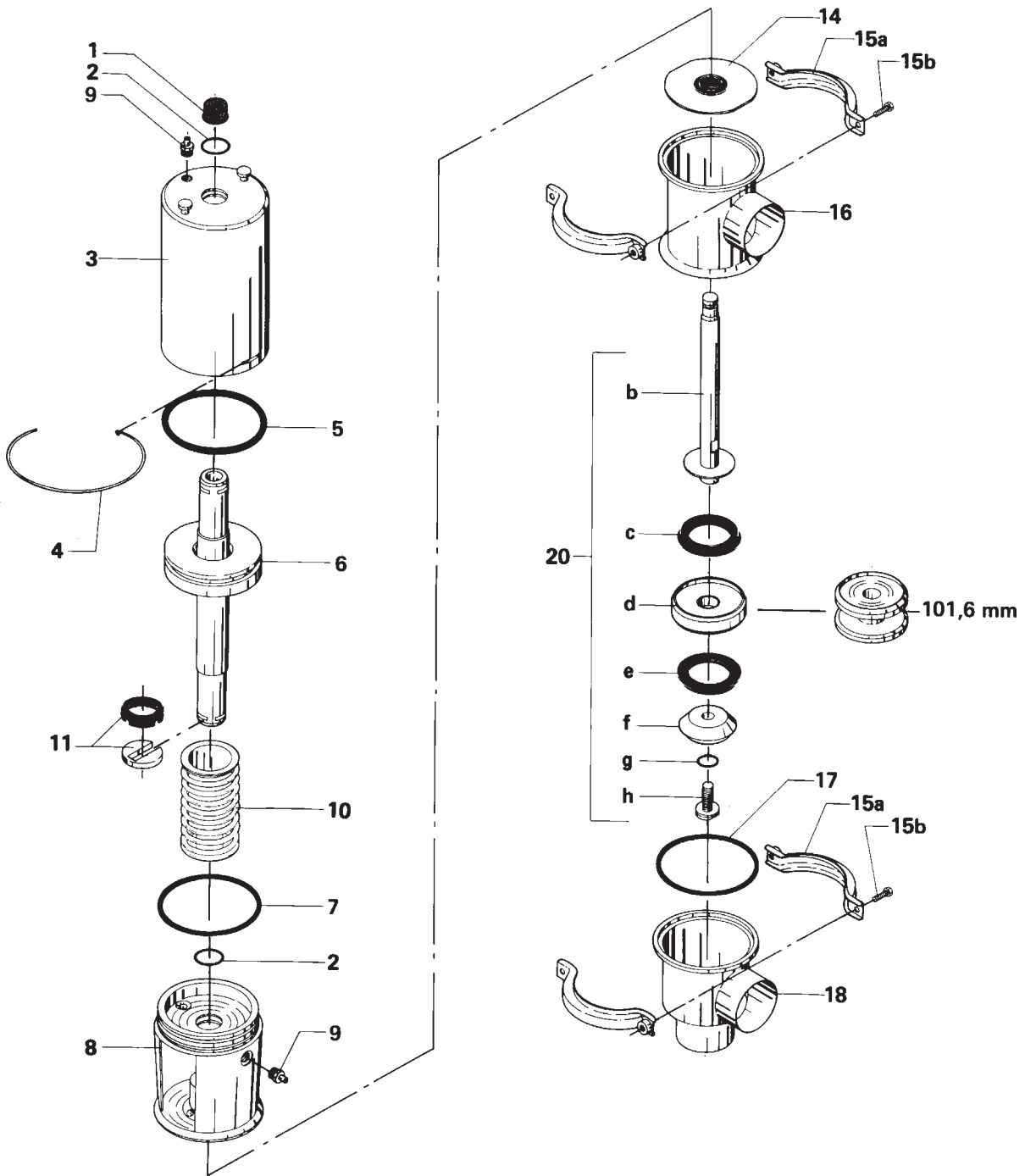

## Drawing/Parts list

The drawings and the parts list include all items.  
NO = Normally open.  
NC = Normally closed.

The items are identical with the items in the Spare Parts List.  
When ordering spare parts, please use the Spare Parts List!

### Parts list SRC-LS - change-over valve

24

Item	Qty.	Denomination
1	1	End cap
2Δ	2	O-ring
3	1	Cylinder
4Δ	1	Lock wire
5Δ	1	O-ring
6	1	Piston
7Δ	1	O-ring
8	1	Bonnet
9◆	2	Plug
10◆	1	Spring assembly
11Δ	1	Clip assembly
14Δ	1	Lip seal
15	2	Clamp half with screw (stop valve)
	4	Clamp half with screw (Change-over valve)
16	1	Valve body, upper
17Δ	1	Valve body seal ring
18	1	Valve body
19	1	Valve plug, single, complete
19a	1	Stem
19eΔ	1	Seal ring
19f	1	Washer
19gΔ	1	O-ring
19h	1	Screw
20	1	Valve plug, double, complete
20b	1	Stem
20c	1	Seal ring, upper
20d	1	Middle piece
20e	1	Seal ring, lower
20f	1	Washer
20g	1	O-ring
20h	1	Screw

Δ : Service kit - EPDM, NBR, FPM  
(See Spare Parts List)

◆ : Only for NO - and NC actuators.

The drawings below show SRC-LS, change-over valve.

The items refer to the parts list on the opposite part of the page.

## Drawings

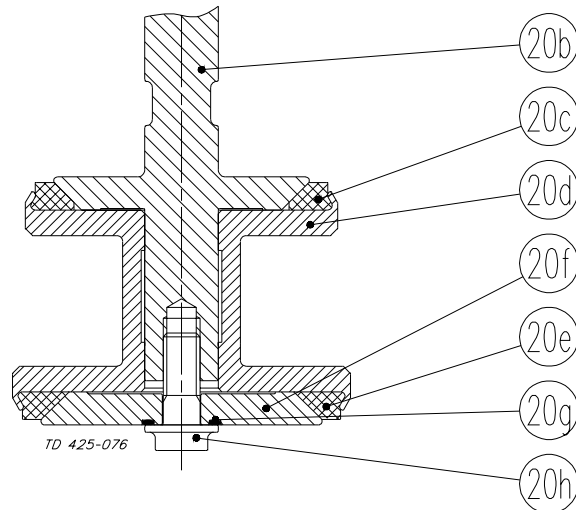
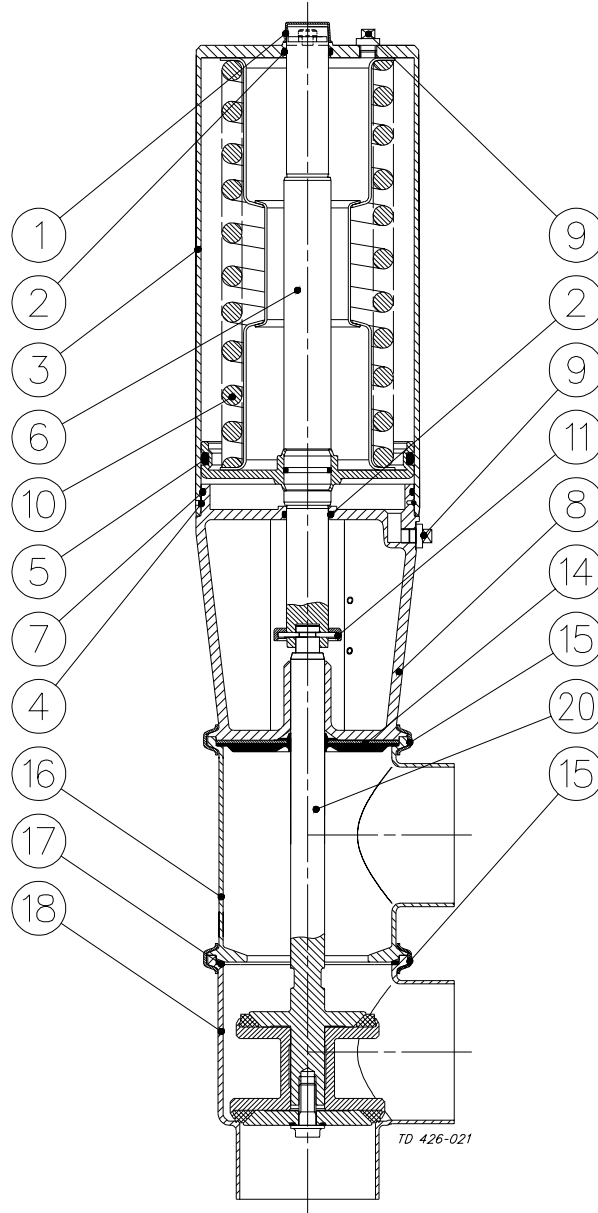

**How to contact Alfa Laval**

Contact details for all countries are continually updated on our website. Please visit [www.alfalaval.com](http://www.alfalaval.com) to access the information direct.